

# TECHON7

## Industrial Touch Screen Computer FT240-M

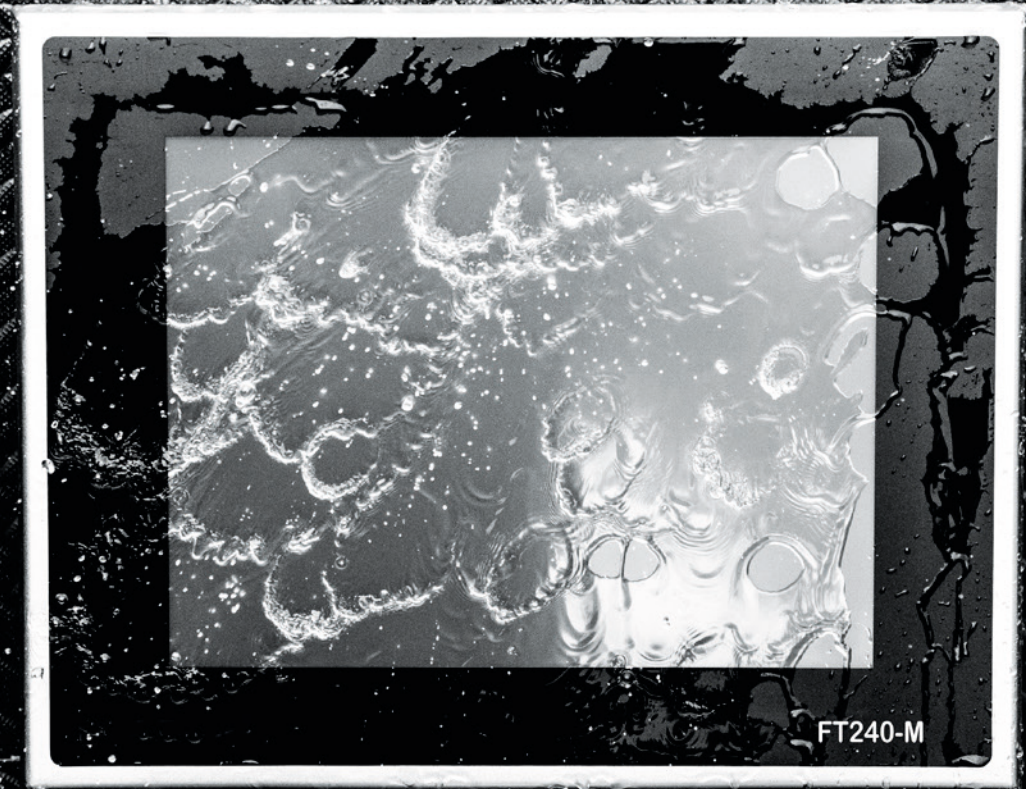

Stainless steel  
Touch Computer  
for industrial use



# Modular design

Our modular design secures, that you have a FT Touch Computer which always are up and running. When your FT Touch Computer breaks down, easily remove the damaged item and switch to a new spare part.

When you need to upgrade your electronics on your FT Touch Computer, ask for our upgrade kit and you now have an updated model.

In our entire FT series you can easily make the products fit your demand. The FT series hold different screen sizes, and the key is that it is the same innerplate holding

all electronics. A complete exchange of system can happen on the production line without having to remove the complete FT Touch Computer. This operation takes less than 10 minutes, resulting in low down time.

The fronts of the FT Touch Computer are likewise one spare part, so an exchange of a broken front can be done in one operation on the production line.

All our accessories is a “one-fit-all” policy.

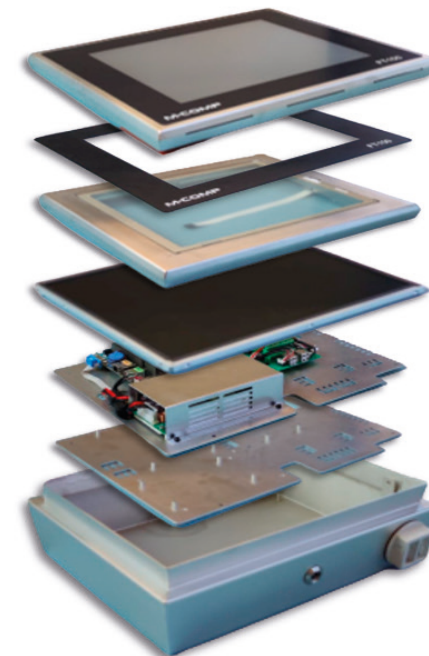

## 7 reasons to choose the FT Terminals

1. Modular design
2. Reliability
3. Performance
4. Repairability
5. Sustainability by refurbishment
6. Produced in Denmark/EU
7. High return on investment



## Reliability

Reliability is a main factor. From early delivery of raw food materials – to production handling - to packing and shipping.

The reliability of the FT products will help you manage the process of work without fallouts and down time.

## Performance

To achieve high and steady performance we have designed a thoroughly thought out built-up, in which all the chosen technology complement each other.

The hardware system in the FT Touch Computers and accessories are developed to ensure a product, that gives you the option to have fully

The FT Touch Computers are developed to work in harsh environments with water, dust and greasy surroundings. They are designed to resist a cleaning process with detergents.

The FT Touch Computers are built to achieve the IP65 standard, which means they are protected from total dust ingress and protected from

functional FT Touch Computer or system, in which you can collect different data, see and control the different processes, monitoring the production output, execute and follow orders and a lot more depending on your software choice and setup. The hardware system includes a powerful Intel Core I3 processor, 4GB RAM and 64GB Solid-state disc and a high reliable power supply.

low pressure water jets from any direction. The standard split gland for cables entry used is IP66.

The FT Touch Computers are built in AISI 316 stainless steel, which is acid resistant and on top of this, it has been treated to give a consistent and nonstick surface. This to ensure a long living and good looking FT Touch Computer.

The combination of the processor and the additional technology in the FT Touch Computers, are developed to ensure that you have a long-lasting product without any breakdowns and major down time.

The FT Touch Computers thereby continuously keep a high, steady and long-lasting performance over time.

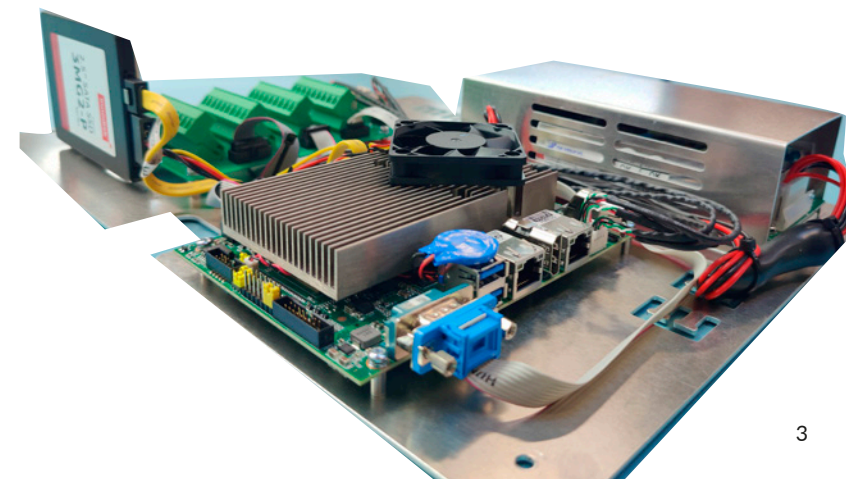

# Repairability & sustainability



## Repairability

The feature of being able to open the FT Touch Computer with a single key in the production environment provides instant access to all parts inside the FT Touch Computer. This makes repairing easy for factories with few or no repair staff.

For any service call you bring either a front or an innerplate and the FT Touch Computer will be back in operation. The collected spare can be sent to us for refurbishment.

With the FT Touch Computers you will be secured spare parts for many years, meaning that our terminals will keep its value as a long-term investment.

Our repair service give extended life to your product. Our on-line system for handling your repair claims, gives you an easy way to register your service request at any time convenient for you.

Once your claim is authorized, you will receive information for your full tracking following the process of your unit from arrival on our site to ship out after repair.

## Sustainability by refurbishment

All components used in the FT Touch Computers are premium quality. All the electronics will last 5 to 10 years, and the cab-

inet as such will last for more than 20 years. For this reason we have introduced our refurb program, where the innerplates can be returned with defects to be refurbished with new items or maybe get upgraded, to ensure vital parts and keeps the product run for years.

Thereby we have less waste to be thrown out, as we recycle all parts possible. Old mechanical parts will be washed and cleaned to be sold as refurbished parts.

From experience the most vulnerable part is the touch screen and its protective film. In our refurb process we exchange the touch screen and the film,

and clean the metal giving new long life to the FT Touch Computers without disposing more parts than necessary. All this to save costs for our customers and to protect the environment.





## High Return On Investment

With the fast moving technology an upgrade on the electronic components has become vital. The main reason for system operators to change hardware, is often due to changes in technology platforms.

In our FT Touch Computer only 50% of the costs are related to the electronics. Therefore it would be a big waste, if the complete FT Touch Computer was thrown out only because of a new CPU was needed.

Our mechanical life cycle is minimum 20 years, and a technology cycle is only 5 years. This gives a good reason to do

upgrades rather than exchange. A technology update are often possible at 1/3 of the cost compared to a new FT Touch Computer, giving a very good ROI on our products.

## Produced in Denmark

By being placed in Denmark we have easy logistic reach to the World. Denmark being a part of the EU, provides free and fast movement of spare parts and refurbished spare parts as well as new products, as no customs declarations are needed.

The workmanship of Danish manufacturing is well recognized world wide as good quality.



# Technical specifications

Display and touch	FT240-M
Size	24" TFT-LCD
Format	16:9
Resolution	1920x1080
LED life time	50.000 Hours
Contrast ratio	5000:1
Luminance	300 cd/m2
Response time	Ton: 16ms Toff: 9ms
Viewing angle	12 o'clock = 89° 9 o'clock = 89° 6 o'clock = 89° 3 o'clock = 89°
Touch type	Resistive touch

I/O	Common features
Serial port	2x RS232 2x RS232/422/485
USB port	4x USB 2.0 2x USB 3.0
Power in	1x IEC C14 power connector (male)
Power out	5VDC 1A

Power supply	Common features
Voltage	9 - 36 VDC
Power consumption	35 Watt

Mechanical and environment	FT240-M
Cabinet	AISI 316 stainless steel
Dimensions (D, H, W)	88mm x 428mm x 689mm
Weight	17,5 kg
IP Code	IP65 (IP68 at cable input)
Working temperature	-10°C to + 35 °C
Storage temperature	-20°C to + 60 °C
Humidity	20% to 95% not condensing
Emission	EN 61000-6-3
Immunity	EN 61000-6-2



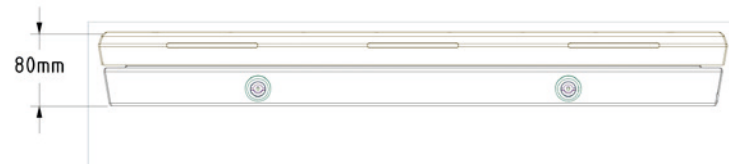
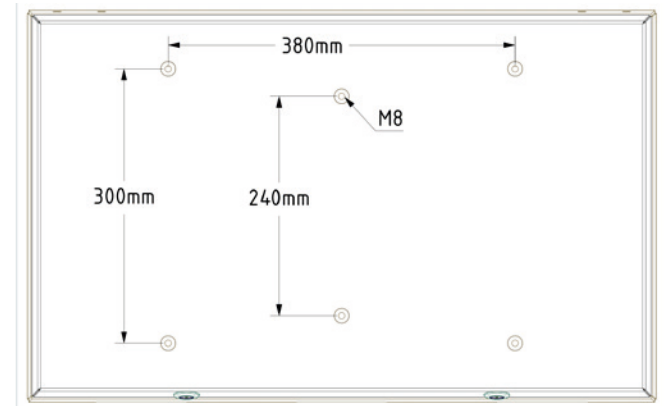
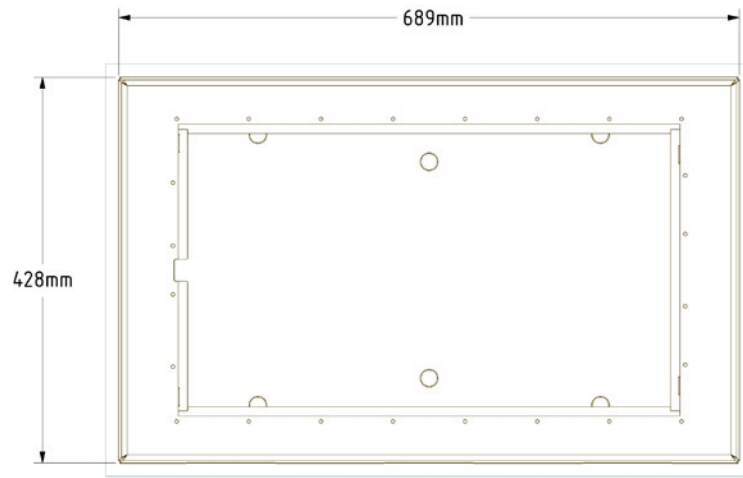

**FT240-M**  
Mechanical drawing

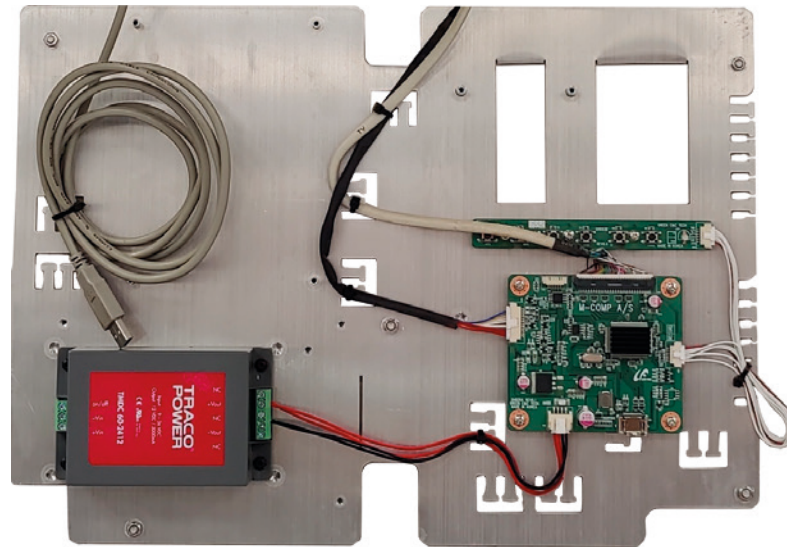

**Connections**  
Mechanical drawing



# FT Accessories

## The floor stand

FTS1 Floor stand gives you the opportunity to place your FT Touch Computer on the floor. Set up the floor stand with four screws into the floor, and then you can mount any of the FT accessories you want directly on the floor stand, including the FT Touch Computers up to 24". Ask for the accessory catalogue to see all the options within accessories for the FTS1 Floor Stand.

Image no.	Part no.	Description
1	14819	FTS1 Floor stand 1.9 meters el.pol
2	14820	FTS2 Keyboard arm el.pol
3	14821	FTS3 Mounting bracket printer shelf, term., keyb. el.pol
4	14822	FTS4 Printer box
5	14823	FTS5 Shelf for printer box el.pol
6	14824	FTS6 Scanner box
7	14825	FTS7 Shelf for scanner box el.pol
8	14826	FTS8 Ringbracket for floor stand el.pol
9	14827	FTS9 Bracket for cable tray
10	14828	FTS10 Cable tray 3.0 meters
11	14829	FTS11 Plate for power outlets
	14830	FTS12 M6 screws w. locknut
	14583	FTS13 Split cable gland - IP54 w. 4 grommets
	14845	FTS14 Split cable gland - IP54 w. 2 grommets

Image no.	Part no.	Description
12	14576	FTS15 Basic bracket el.pol
	14598	FTS16 Main power cable - 3.2 meters, 230V, EU
13	14855	FTS17 IT box plate
	15118	FTS18, Water-proof stylus pen
14	15153	FTS19 Mennekes 9301 CEE wall mounted socket 3-pol 16A 230V IP67
	13598	FTS20 Fod for terminal DC - 121016-77
	15223	FTS21 Man & Machine REALLYCOOLIP68 Medical Keyboard
	15222	FTS22 ActiveKey medical mouse with scroll wheel sensor IP68
	15252	FTS23 M8 screws w. locknut



## FT Brackets



**FT Wall mount**  
Part no. 15224

FT Wall mount is easy to install and to service. When you have installed your FT Wall mount, you can attach your FT Touch Computer with a keyboard and mouse. See our accessories brochure for more details on the keyboard set.

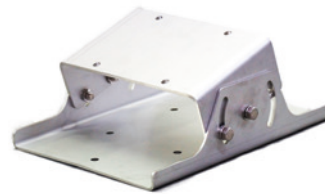

**FT1 Wall mount 1-Axis**  
Part no. 14584

FT1 Wall mount is easy to install and to service. When you have installed your FT1 Wall mount, you can attach your FT Touch Computer. The FT1 Wall mount can be adjusted horizontally.



**FT2 Wall mount 2-Axis**  
Part no. 14585

FT2 Wall mount is easy to install and to service. When you have installed your FT2 Wall mount, you can attach your FT Touch Computer. The FT2 Wall mount can be adjusted horizontal and vertically.

# Technical solutions for your needs right now – and in the future

TECHON7 has a wide product program of Industrial Touch Screen Computers for food production and other industries. Our program of ruggedized industrial computer solutions can be used in various harsh environments from water to chemicals and dust. Our solid solutions meet several specific requirements, and the modular concept ensures reliability, repairability, and performance. Together we achieve more.

## Our process brings value to your business

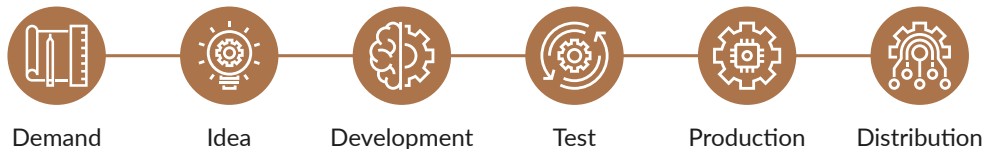

## When Knowhow Matters

Techon7 ApS  
Spettrupvej 1C | DK-8722 Hedensted  
+45 7060 2777 | techon7.dk

Through customer insight and competent knowledge we develop and integrate modular components for innovative developers in industries, who aim for reliable and future-proof solutions

